

**SELECT PROGRAM:**

2<sup>nd</sup>

LRN

0

1

SBR

CLR

- List: Frontal Area \_\_\_\_\_ ENTER
- List: Driveline & Altitude Efficiency \_\_\_\_\_ ENTER
- List: Gross Weight or Combination Weight \_\_\_\_\_ ENTER
- List: Desired Road Speed \_\_\_\_\_ ENTER
- List: Grade (%) \_\_\_\_\_  
plus Road Surface Factor \_\_\_\_\_

Solve for Net Horsepower required:

PRESS   and list result \_\_\_\_\_

**Alternate Procedures:**

ENTER any set of five known values, and solve for the unknown sixth.

**WORK SHEET—PROGRAM #1  
PERFORMANCE**

# ROAD SURFACE CORRECTION FACTOR

Road Surface	Correction Factor (RSF)
Best Concrete.....	0
Worn Concrete.....	
Asphaltic concrete (cold).....	.2
Sheet Asphalt (cold).....	
Brick.....	
Packed gravel, clay bound.....	.5
Asphaltic concrete in summer heat.....	
Hard packed natural soil.....	.75
Average packed gravel.....	1.0
Sheet asphalt in summer heat.....	
Packed natural soil, spongy.....	2.25
Loose Gravel.....	7.75
Sand.....	11.5

©2010 Joerg Woerner  
 Datamath Calculator Museum

**SELECT PROGRAM:**



List: Engine Revolutions per Minute

List: Rear Axle Ratio

List: Transmission Ratio

List: Auxiliary Transmission Ratio

List: Tire Revolutions per Mile

_____	ENTER	RPM
_____	ENTER	R
_____	ENTER	T
_____	ENTER	AT
_____	ENTER	R/M

Solve for speed in Miles per Hour:

PRESS  , and list result \_\_\_\_\_

**Alternate Procedures:**

ENTER any set of five known values, and solve for the unknown sixth.

© 2010 Joerg Woerner  
Datamath Calculator Museum

**WORK SHEET—PROGRAM #2  
SPEED & GEARING**

# DRIVELINE & ALTITUDE EFFICIENCY CHART

Engine	Driveline Type				Altitude (Ft.)																		
	Main Trans. Speeds	Aux. Trans. Speeds	No. of Drive Axles	Four Wheel Drive (a)	Drive Line Efficiency	Sea Level																	
							500	1000	1500	2000	2500	3000	3500	4000	4500	5000	5500	6000	6500	7000	8000	9000	10000
Four-Cycle	Altitude Correction Only					1.00	.98	.96	.94	.92	.90	.88	.86	.84	.82	.80	.78	.76	.74	.72	.68	.64	.60
	3, 4, 5	None	Sgl.	—	.90	.88	.86	.85	.83	.81	.79	.77	.76	.74	.72	.70	.68	.67	.65	.61	.58	.54	
	3, 4, 5	None	Dual	—	.86	.84	.83	.81	.79	.77	.76	.74	.72	.71	.69	.67	.65	.64	.62	.58	.55	.52	
	10, 12, 16	None	Sgl.	—	.85	.83	.82	.80	.78	.76	.75	.73	.71	.70	.68	.66	.65	.63	.61	.58	.54	.51	
	10, 12, 16	None	Dual	—	.82	.80	.79	.77	.75	.74	.72	.71	.69	.67	.66	.64	.62	.61	.59	.56	.52	.49	
	3, 4, 5	2, 3, 4	Sgl.	—	.84	.82	.81	.79	.77	.76	.74	.72	.71	.69	.67	.66	.64	.62	.60	.57	.54	.50	
Two-Cycle	Altitude Correction Only					.84	.82	.81	.79	.77	.76	.74	.72	.71	.69	.67	.66	.64	.62	.60	.57	.54	.50
	3, 4, 5	2, 3, 4	Dual	—	.80	.78	.77	.75	.74	.72	.70	.69	.67	.66	.64	.62	.61	.59	.58	.54	.51	.48	
	Altitude Correction Only					1.00	.99	.985	.98	.97	.965	.955	.947	.94	.932	.925	.917	.907	.90	.88	.87	.85	.83
	3, 4, 5	None	Sgl.	—	.90	.89	.89	.88	.87	.87	.87	.85	.85	.84	.83	.83	.82	.81	.79	.78	.76	.75	
	3, 4, 5	None	Dual	—	.86	.85	.85	.84	.83	.83	.82	.81	.81	.80	.80	.79	.78	.77	.76	.75	.73	.71	
	10, 12, 16	None	Sgl.	—	.85	.84	.84	.83	.82	.82	.81	.80	.80	.79	.79	.78	.77	.76	.75	.74	.72	.71	
Four-Cycle	10, 12, 16	None	Dual	—	.82	.81	.81	.80	.80	.79	.78	.78	.77	.76	.76	.75	.74	.74	.72	.71	.70	.68	
	3, 4, 5	2, 3, 4	Sgl.	—	.84	.83	.83	.82	.81	.81	.80	.80	.79	.78	.78	.77	.76	.76	.74	.73	.71	.70	
	Altitude Correction Only					.84	.83	.83	.82	.81	.81	.80	.80	.79	.78	.78	.77	.76	.76	.74	.73	.71	.70
	3, 4, 5	2, 3, 4	Dual	yes	.84	.83	.83	.82	.81	.81	.80	.80	.80	.79	.78	.78	.77	.76	.76	.74	.73	.71	.70
	3, 4, 5	2, 3, 4	Dual	—	.84	.83	.83	.82	.81	.81	.80	.80	.80	.79	.78	.78	.77	.76	.76	.74	.73	.71	.70
	3, 4, 5	2, 3, 4	Dual	—	.80	.79	.79	.78	.78	.77	.76	.76	.75	.75	.74	.73	.73	.72	.70	.70	.68	.66	

(a) Engaged or disengaged.

**SELECT PROGRAM:**



- List: Road Surface Correction Factor      \_\_\_\_\_      ENTER      **RSF**
- List: Gross Weight or Combination Weight      \_\_\_\_\_      ENTER      **GW**
- List: Transmission Ratio      \_\_\_\_\_      ENTER      **T**
- List: Auxiliary Transmission Ratio      \_\_\_\_\_      ENTER      **AT**
- List: Rear Axle Ratio      \_\_\_\_\_      ENTER      **R**
- List: Tire Revolutions per Mile      \_\_\_\_\_      ENTER      **R/M**
- List: Engine Net Torque—Lb. Ft.      \_\_\_\_\_      ENTER      **TQ**

Solve for Gradeability in percent:

PRESS **CLR** **G** and list result \_\_\_\_\_

(Note: This value represents *rolling* gradeability at speeds less than 30 MPH.  
For *starting* gradeability, subtract 10.0.)

**Alternate Procedures:**

ENTER any set of seven known values, and solve for the unknown eighth.

**WORK SHEET—PROGRAM #3  
GRADEABILITY**

## SINGLE TIRE RATINGS—TRUCK TYPE TIRES

Tire Size		Ply Rating	Load Range	Average Rev's Per Mile (a)	Loaded Radius (in.)
Tubeless	Tube				
—	7.00/20	8	D	587	16.9
—	7.00R20	8	D	587	16.9
—	7.00/20	10	E	587	17.2
—	7.00R20	10	E	587	17.2
8-22.5	7.50/20	8	D	570	17.7
8R22.5	7.50R20	8	D	570	17.7
8-22.5	7.50/20	10	E	570	17.7
8R22.5	7.50R20	10	E	570	17.7
9-22.5	8.25/20	10	E	545	18.3
9R22.5	8.25/20	10	E	545	18.3
9-22.5	8.25/20	12	F	545	18.3
9R22.5	8.25R20	12	F	545	18.3
10-22.5	9.00/20	10	E	523	19.4
10R22.5	9.00R20	10	E	523	19.4
10-22.5	9.00/20	12	F	523	19.4
10R22.5	9.00R20	12	F	523	19.4
11-22.5	10.00/20	12	F	504	19.6
11R22.5	10.00R20	12	F	504	19.6
11-22.5	10.00/20	14	G	505	19.6
11R22.5	10.00R20	14	G	505	19.6
12-22.5	11.00/20	12	F	493	20.2
12R22.5	11.00R20	12	F	493	20.2
12-22.5	11.00/20	14	G	493	20.2
12R22.5	11.00R20	14	G	493	20.2
11-24.5	10.00/22	12	F	482	20.6
11R24.5	10.00R22	12	F	482	20.6
11-24.5	10.00/22	14	G	482	20.6
11R24.5	10.00R22	14	G	482	20.6
12-24.5	11.00/22	12	F	470	21.1
12R24.5	11.00R22	12	F	470	21.1
12-24.5	11.00/22	14	G	470	21.1
12R24.5	11.00R22	14	G	470	21.1
—	11.00/24	14	G	451	22.0
—	11.00R24	16	H	448	22.0
—	11.00R24	14	G	451	22.0
—	12.00-20	14	G	473	22.1
—	12.00R20	18	J	476	20.4
—	12.00-24	16	H	433	22.9
—	12.00R24	16	H	430	22.9
15-22.5	—	14	G	484	19.8
15-22.5	—	16	H	484	19.8
16.5-22.5	—	16	H	467	20.5
18-19.5	—	16	H	491	18.0
18-22.5	—	16	H	458	20.9
18-22.5	—	18	J	458	20.9

**SELECT PROGRAM:**

**2nd**

**LRN**

**0**

**4**

**SBR**

**CLR**

Wheelbase, inches (from Data Book)

\_\_\_\_\_ ENTER **WB**

List: Weight of Body \_\_\_\_\_

Weight of Payload \_\_\_\_\_

Body & Payload Weight =

\_\_\_\_\_ ENTER **W**

List: Cab-to-Axle Dimension, inches

1/2 Body Length, inches \_\_\_\_\_

plus Cab-to-Body Clearance \_\_\_\_\_

equals

\_\_\_\_\_ = \_\_\_\_\_

Subtracted from CA, equals

\_\_\_\_\_ ENTER **CGA**

FRONT REAR

List Chassis Weights (from Data Book)

PRESS **WF** and list result

PRESS **CLR** **WR** and list result

Add to produce:

Total Axle Weights \_\_\_\_\_

Gross Vehicle Weight \_\_\_\_\_

© 2010 Joerg Woerner  
Datamath Calculator Museum

**WORK SHEET—PROGRAM #4  
LOAD DISTRIBUTION**

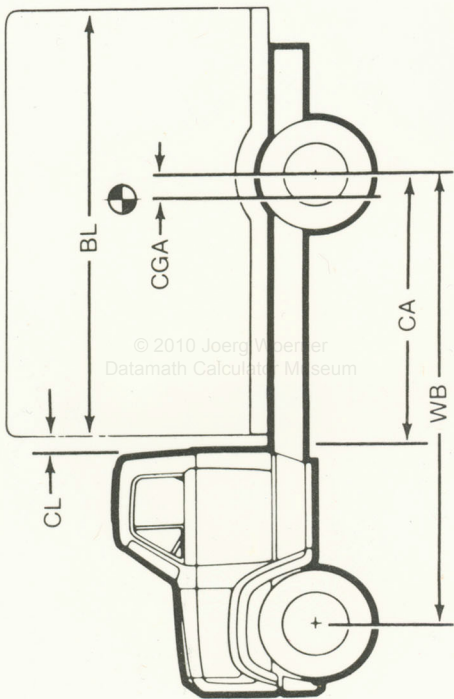

# SELECT PROGRAM:

2nd

LRN

0

5

SBR

CLR

List: Tractor length, inches \_\_\_\_\_, minus KP \_\_\_\_\_, minus O.H. \_\_\_\_\_, = \_\_\_\_\_ ENTER **TWB**  
 List: 1/2 Tractor Length, inches \_\_\_\_\_, minus O.H. \_\_\_\_\_, = \_\_\_\_\_ ENTER **CGA**  
 List: Payload in pounds \_\_\_\_\_ ENTER **PL** **CLR**

PRESS **KPL**, list result \_\_\_\_\_  
 List: Weight of empty trailer at KP \_\_\_\_\_  
 Add to produce:  
 List: Wheelbase of tractor, inches \_\_\_\_\_ ENTER **KPW**  
 List: Distance Fifth Wheel ahead of rear axle(s) \_\_\_\_\_ ENTER **WB**  
 \_\_\_\_\_ ENTER **AF** **CLR**

FRONT DRIVE TRAILER

List: Tractor weights (from Data Book) \_\_\_\_\_  
 PRESS **TSA**, list result \_\_\_\_\_  
 PRESS **TDA**, list result \_\_\_\_\_  
 PRESS **TPL**, list result \_\_\_\_\_  
 List: Weight of empty trailer at trailer axle(s) \_\_\_\_\_

Add to produce:  
 Gross Weight at Axle(s) \_\_\_\_\_  
 Gross Combination Vehicle Weight \_\_\_\_\_  
 (Total, All Axles) \_\_\_\_\_

© 2010 Joern Woerner  
 Datamath Calculator Museum

## WORK SHEET—PROGRAM #5 TRACTOR/TRAILER WEIGHT DISTRIBUTION

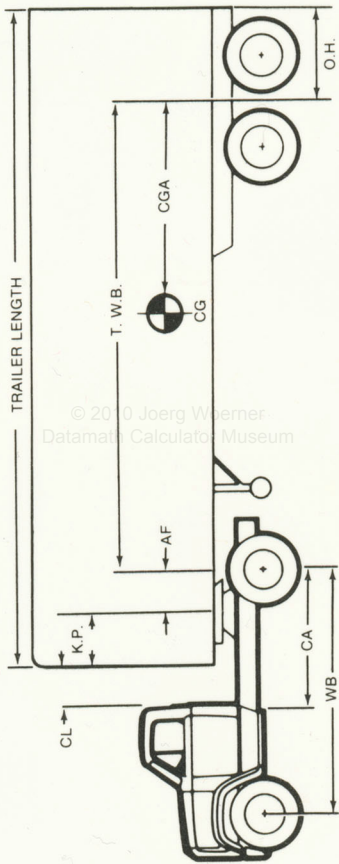

© 2010 Joerg Woerner  
 Datamath Calculator Museum

**SELECT PROGRAM:**

2<sup>nd</sup>

LRN

0

6

SBR

CLR

- List: Number of Trips per Year \_\_\_\_\_ ENTER **T/YR**
- List: Revenue Rate per 100 Pounds \_\_\_\_\_ ENTER **CWT**
- List: Percent of Over-the-Road Costs \_\_\_\_\_ ENTER **%/OR**
- List: Useful Life Equipment Years \_\_\_\_\_ ENTER **LIFE**
- List: Percentage, Tax Bracket \_\_\_\_\_ ENTER **TAX**
- List: Interest Rate Percentage \_\_\_\_\_ ENTER **INT**
- List: Cost of Weight Savings, Dollars \_\_\_\_\_ ENTER **CWS**
- List: Pounds of Weight Saved \_\_\_\_\_ ENTER **LBS**

Solve for:

Additional Revenue over useful life of equipment, in present-value after-tax dollars.

PRESS **REV** , list result \_\_\_\_\_

© 2010 Joerg Woerner  
Datamath Calculator Museum

## WORK SHEET—PROGRAM #6 WEIGHT SAVINGS/COST RATIOS

## AVERAGE FRONTAL AREA

Light Duty Conventional Cabs 1500/3500 = 38 sq. ft.

Medium Duty Conventional Cabs 5000/7000 = 50 sq. ft.

Average Frontal Area Vehicle with Body or Trailer (8 Ft. Wide):

Body Height Top to Ground (Ft.)	Frontal Area Sq. Ft.	Body Height Top to Ground (Ft.)	Frontal Area Sq. Ft.
6	44	9	68
6½	48	9½	72
7	52	10	76
7½	56	10½	80
8	60	11	84
8½	64	11½	88
		12	92
		12½	96
		13	100
		13½	104
		14	108

**SELECT PROGRAM:**



**WORK SHEET—PROGRAM #7  
FUEL COST ANALYSIS**

List: Price per Gallon of Fuel, Dollars

List: Miles of Operation per Year

List: Hours of Engine Idle per Year

List: \*Mileage Equivalent per Hour of Idle

List: Miles per Gallon of Fuel

Solve for Fuel Cost per Year, Dollars

Present

ENTER \_\_\_\_\_ **PPG** \_\_\_\_\_ Proposed

ENTER \_\_\_\_\_ **M/YR** \_\_\_\_\_

ENTER \_\_\_\_\_ **I/YR** \_\_\_\_\_

ENTER \_\_\_\_\_ **H/EQ** \_\_\_\_\_

ENTER \_\_\_\_\_ **MPG** \_\_\_\_\_

PRESS \_\_\_\_\_ **C/YR** \_\_\_\_\_

Annual Net Savings

Total Savings Over \_\_\_\_\_ Years

\*Assumptions: Mileage Equivalent Per Hour Of Idle

Gasoline Engine = 10

Diesel Engine = 5

# Glossary of Symbols

A	= Frontal Area in Square Feet
AF	= Distance Fifth Wheel ahead of Rear Axle(s)
AT	= Auxiliary Transmission Ratio
CGA	= Center of Gravity (Body & Payload) ahead of Rear Axle(s)—inches
CWS	= Cost of Weight Savings, Dollars
CWT	= Revenue Rate per 100 Pounds
C/YR	= Fuel Cost per Year, Dollars
DAE	= Driveline and Altitude Efficiency
G	= Grade in Percent
GW	= Gross Weight or Combination Weight-Pounds
H/EQ	= Mileage Equivalent per Hour of Idle
INT	= Interest Rate
I/YR	= Hours of Engine Idle per Year
KPL	= Weight of Payload at Kingpin
KPW	= Total Weight (KPL + Trailer Weight) at Kingpin
LBS	= Pounds of Weight Saved
LIFE	= Useful Life of Equipment, Years
MPG	= Miles per Gallon of Fuel
MPH	= Speed in Miles per Hour
M/YR	= Miles of Operation per Year
NHP	= Net Horsepower
%/OR	= Percent of costs to Over-the-Road
PL	= Payload, in pounds
PPG	= Price per Gallon of Fuel, Dollars
R	= Rear Axle Ratio
REV	= Additional Revenue, over useful life of equipment
R/M	= Tire Revolutions per Mile
RPM	= Engine Revolutions per Minute
RSF	= Road Surface Correction Factor
T	= Transmission Ratio
TAX	= Percentage, Tax Bracket
TDA	= Weight transferred to Tractor Drive Axle(s) from Kingpin
TPL	= Weight of Payload at Trailer Axles
TQ	= Engine Net Torque—Lb. Ft.
TSA	= Weight transferred to Tractor Steering Axle from Kingpin
TWB	= Trailer Wheelbase, inches
T/YR	= Number of Trips per Year
W	= Any Weight to be distributed between two or more axles
WB	= Wheelbase in inches
WF	= Weight transferred to Front Axle
WR	= Weight transferred to Rear Axle(s)